



**L-1X / L-1X16**  
 Chemical Sanitizing  
 Undercounter  
 Dishwasher

**MODEL L-1X**



**MODEL L-1X16**

**FEATURES:**

- 30 racks / 120 covers per hour.
- Economical to operate. Uses only 1.7 gallons of water per cycle.
- All stainless steel construction assures long life and years of trouble free operation.
- 16" door opening on the (L-1X16) allows the washing of larger items. (L-1X) door opening 12-1/8".
- Unique spray arm system features upper and lower stainless steel wash arms with reinforced end caps.
- Built-in chemical pumps and delimiting system assures proper chemical usage.
- Convenient to service "Work-in-a-drawer". All electrical components are attached to a sliding drawer for easy access and service.
- Pumped drain allows for flexible installation. Requires no floor drain.
- Pump purging system improves results by eliminating soil and chemical carryover during rinse cycle.
- Stainless steel pump impeller. Offers extended life and service.
- Built-in strainer in water inlet system to prevent water valve from clogging.
- Two dishracks included.
- Built-in primer switches.
- Built-in instant start.
- Door safety switch makes operation safe.



Optional dishtable and faucet.

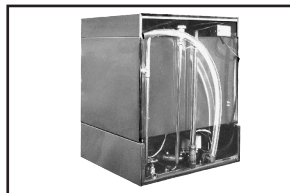

Pumped drain will drain uphill. Requires no floor drain.

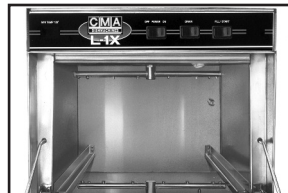

Upper and lower rotating wash arms guarantee excellent results.

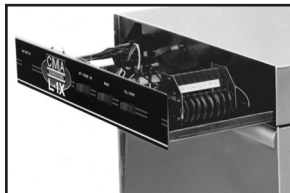

"Work-in-a-drawer", may be removed.



The optional Universal Pedestal has a storage feature for spare dishracks, with the ability to store two empty dishracks beneath the machine. 15-1/4"H X 24"W X 25-1/4"D.

**Available Options**

- Sustainer Heater
- Sanitizer Alarm
- The "TEMP-SURE" requires a separate 208-240v 3 phase 40 amp power supply
- Stainless Steel Legs 6" (set of 4)
- Stainless Steel Pedestal
- 48" Undercounter dishtable with Pre-Rinse
- Alternative electrical available for export





# L-1X / L-1X16

Chemical Sanitizing  
Undercounter  
Dishwasher

**WARNING:** Plumbing connections must be made by a qualified service company who will comply with all available Federal, State, and Local Health, Plumbing and Safety codes.

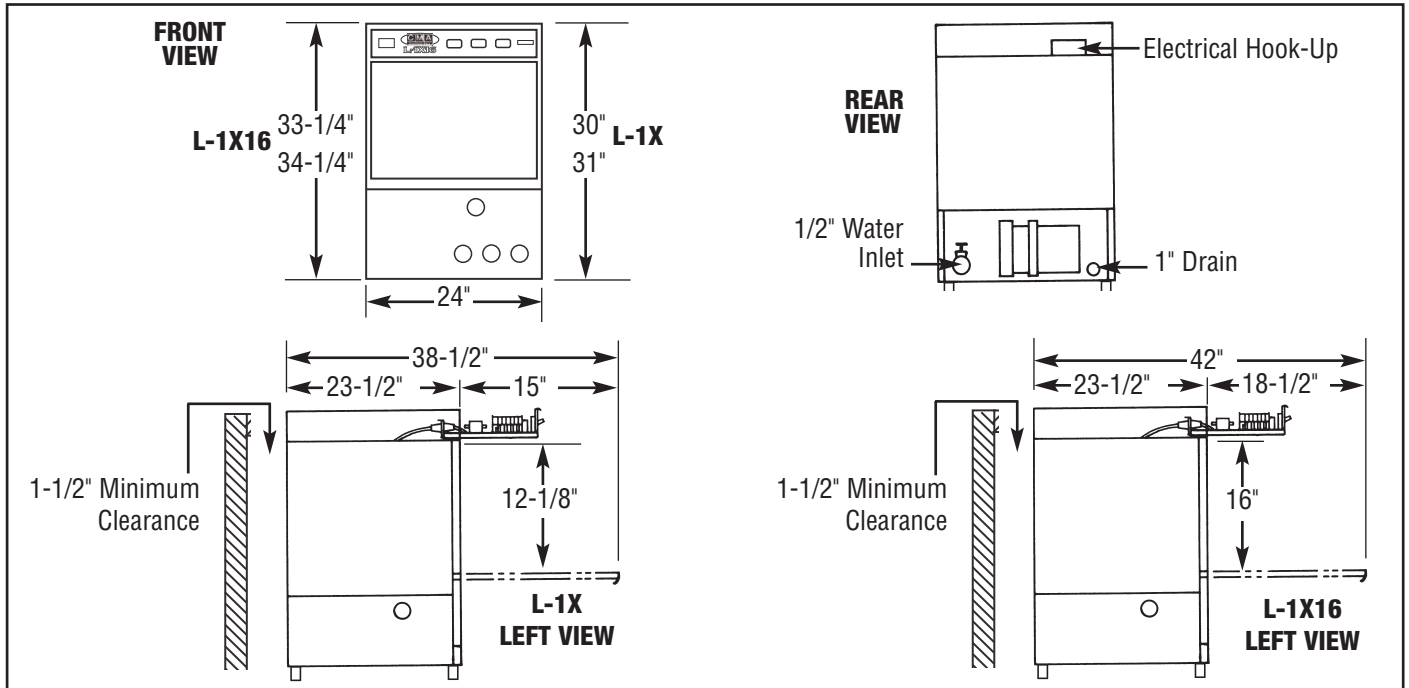

**Specifications:**

UNDERCOUNTER DISHWASHER	L-1X/L-1X16	METRIC	USA	METRIC
<b>OPERATING CAPACITY</b>				
RACKS PER HOUR (NSF RATED)	30	30		
<b>OPERATING CYCLE</b>				
WASH TIME-SEC	58	58		
RINSE TIME-SEC	32	32		
DWELL/PURGE-SEC	30	30		
TOTAL CYCLE TIME	120	120		
WASH TANK CAPACITY	1.7 GAL.	(6.49 L)		
WASH PUMP CAPACITY	35 GPM	(132.5 LPM)		
<b>OPERATING TEMPERATURE</b>				
REQUIRED	120°F	(49°C)		
RECOMMENDED	140°F	(60°C)		
<b>WATER CONSUMPTION</b>				
PER RACK	1.7 GAL.	(6.44 L)		
PER HOUR	40.8 GAL.	(154.4 L)		
WATER INLET	1/2"	(1.27 cm)		
DRAIN	1"	(2.54 cm)		
<b>WASH PUMP MOTORS HP</b>			1	1
<b>DIMENSIONS</b>				
DEPTH			23-1/2"	(59cm)
WIDTH			24"	(61cm)
HEIGHT			33-1/4"-34-1/4" (L-1X16)	(84-86 cm)
HEIGHT			30"-31" (L-1X)	(76.2-78.2 cm)
MAXIMUM CLEARANCE HEIGHT FOR DISHES			16" (L-1X16)	(40.64cm)
MAXIMUM CLEARANCE HEIGHT FOR DISHES			12-1/8" (L-1X)	(31cm)
<b>STANDARD DISHRACK</b>			1	1
DIMENSIONS			19-3/4"X19-3/4"	(50X50cm)
<b>ELECTRICAL RATING</b>			<b>VOLTS</b>	<b>AMPS</b>
			115	16
<b>SHIPPING WEIGHT</b>				
APPROXIMATE			196#	(88kg)

**Summary Specifications: Models L-1X / L-1X16**

CMA Energy Miser models L-1X and L-1X16 low temperature undercounter chemical sanitizing commercial dishwashers meets NSF, UL and CUL sanitation and construction standards WITHOUT the use of BOOSTER or TANK HEATERS. The models L-1X and L-1X16 is constructed entirely of stainless steel. Each unit automatically washes, rinses and sanitizes food service utensils in standard 19-3/4"X19-3/4" racks. Units comes standard with upper and lower stainless steel wash arms. The L-1X and L-1X16 incorporates a pump purging system that improves results by eliminating soil and chemical carryover during rinse cycle.

