



E88820-00



HF14

14" Upright Vacuum with HEPA Filter



Operator and Parts Manual

TABLE OF CONTENTS

TECHNICAL INFORMATION	3
GENERAL SAFETY INFORMATION	4 - 5
MACHINE PREPARATION AND OPERATION	6 - 7
MAINTENANCE	8 - 9
MACHINE DIAGRAM AND PARTS LISTING	10 - 13
WIRING DIAGRAM.....	14
WARRANTY	16

TECHNICAL DESCRIPTION	Measurement Unit	HF14
Vacuum Motor Power	Watts	1000
Brush Motor Power	Watts	250
Dust Bag Capacity	Gallons	1.2
Working Surface	Inches	14
Weight	Lbs.	15
Noise Level	dB(A)	67
Voltage	Volt / HZ	120 Volt / 60 HZ

GENERAL SAFETY INFORMATION

PACKAGING

- The box and packaging materials have been designed to protect the appliance during shipping and are biodegradable and recyclable. Please dispose of these items as you would any other product that can be recycled.

USED VACUUM CLEANER

- The symbols for the materials used to manufacture parts and accessories, and the recycle symbols, are located on the parts themselves, where there is room to do so. Old vacuum cleaners may contain materials that can be re-used or recycled.

IMPORTANT SAFETY MEASURES

When using an electrical appliance, there are several basic precautions to be taken at all times, including:

- Always read all of the instructions for use before using the appliance.
- Always abide by these safety instructions.
- Never use the appliance on people or animals.

IMPORTANT: TO REDUCE THE RISK OF FIRE, ELECTRIC SHOCK OR INJURY:

- Check the voltage stated on the vacuum cleaner before connecting the power cable to the main power supply; the main voltage needs to be the same as the voltage stated on the appliance rating plate, which is located on the bottom of the vacuum cleaner. If you are not sure of your power supply voltage, please check with a qualified electrician.
- A damaged vacuum cleaner can be dangerous. Check the packaging, the vacuum cleaner and the attachments for any signs of damage. Never use a damaged appliance.
- Never leave the vacuum cleaner plugged into the main power. Unplug the cleaner when not in use or before carrying out any cleaning or maintenance to the appliance itself.
- Only use the vacuum cleaner on dry surfaces; do not use it outdoors, on wet surfaces or to clean up any type of liquid. Do not use this appliance to clean up liquids as this could reduce the electrical safety of the cleaner. This also applies in the case of carpets that have just been washed: wait until they are dry.
- Do not allow the vacuum cleaner to be used as a toy. Take care if it is used by or near children.
- If the power cable rewind or the cable itself are damaged, they should be replaced only by an authorised after-sales assistance service. Never use the vacuum cleaner with a damaged cable or plug.
- If the appliance does not operate correctly or if it has been dropped or damaged, left outdoors or immersed in water, take it to your retailer or to an after sales assistance service.
- For any repairs or to purchase parts or accessories, please contact your retailer or an authorised technical service centre. Do not try to carry out repairs yourself.
- Do not pull or carry the vacuum cleaner by the cable; do not use the cable as a handle; do not close the cable in doors or pull it across sharp edges or around corners. Never pass the appliance over the cable. Keep the cable well away from hot surfaces.
- Do not unplug the appliance by pulling on the power cable: grip the plug and not the cable. Do not touch the cable or the appliance with wet hands.
- Always keep hair, clothing, fingers and all other body parts well away from openings and moving parts.
- Set the switch to OFF after use.
- Take special care when cleaning stairs.
- When using this appliance with an accessory always remove the plug from the electric socket before attaching any rotating brush. In any case, never touch the rotating brush while it is operating.
- Do not pass attachments over the appliance power cable or any extension lead.
- Do not clean up sharp objects.
- Always switch off the appliance before fitting or removing the hose.
- The poles in the plug and the contacts in the power socket must never come into contact with water. These parts can only be wiped clean with a dry cloth and must not be allowed to come into contact with moisture. Danger of electric shock.

GENERAL SAFETY INFORMATION

- Only wipe the appliance clean with a dry (or very slightly damp) cloth while it is unplugged. Never place the appliance in water.
- Never clean up anything that is burning or smoking, such as cigarettes, matches, hot ash, etc.
- Never place any items in the appliance openings. Never use the vacuum cleaner with openings blocked in any way; keep them free from dust, dirt, hair and anything else that might reduce air flow.
- Do not clean up toner powder. The toner used in printers and copiers can conduct electricity.
- Do not use the vacuum cleaner without a dust bag and/or without the filters in place. Dust bags need to be disposed of and can be used only once. Do not try to re-use them.

IMPORTANT: The manufacturer cannot accept any liability for damage to people or property caused by improper use, maintenance carried out by persons without the proper authorisation, the use of non-original or unauthorised spare parts, or any form of tampering with and/or changes made to the original product.

The manufacturer reserves the right to make changes to the appliance and/or accessories supplied without any prior notice.

MACHINE PREPARATION AND OPERATION

- 1 Ergonomic handgrip
- 2 Power cable
- 3 Hose
- 4 Telescopic extension
- 5 Switch
- 6 Carrying handle
- 7 Cord Wrap Hooks
- 8 Hatch
- 9 Air vent
- 10 Motor housing
- 11 Electric brush
- 12 Base

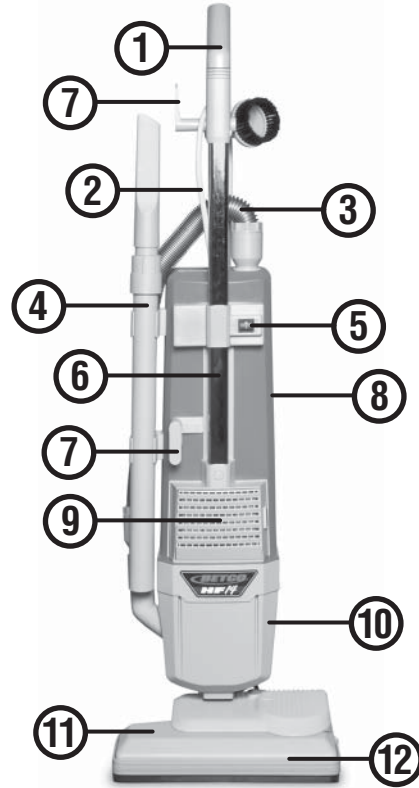

2. CONNECTING THE HOSE

Insert the straight coupling into the dust bag container hole: insert the angled coupling into the side slot of the motor housing.

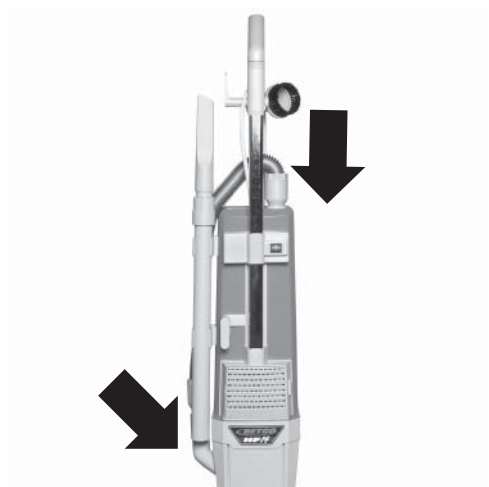

3. TELESCOPIC EXTENSION OPERATION

Pull out the extension and lock it by turning the special collar in a counter-clockwise direction.

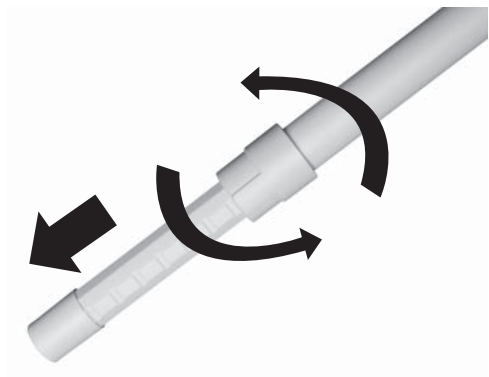

MACHINE PREPARATION AND OPERATION

4. STARTING UP THE BRUSH

To operate: Use your foot to press the cover (A) and lower the cleaner at the same time.

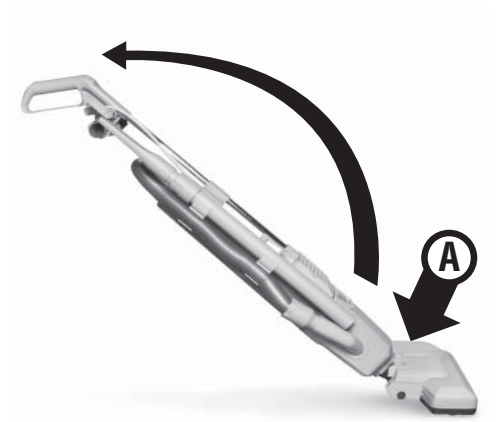

5. CHECKING THE BRUSH

The brush control device constantly checks the brush operation:

- Green light: the brush is operating correctly Red light: the brush is blocked or subject to excessive stresses. Switch off the cleaner, remove the mains plug and check the cause of the blockage.
- Simultaneous red and green lights: roller worn out: to be replaced.



6. FILTER-FULL INDICATOR

If the Full Bag Indicator turns red, check the following:

- a) if the dust bag is full
- b) if the brush is obstructed
- c) if the suction tube is obstructed; in this case, remove the obstruction
- d) if the Hepa filter is completely obstructed during suction, it is normal for the bag full indicator to turn partly red, since the tube is almost completely closed.



MAINTENANCE

1. FILTER DUST BAG REPLACEMENT

Remove the hatch. Place paper bag in the container, inserting the bag support fitting into the hole in the bag and pushing the safety ring as far as it will go. If the filter bag is not correctly positioned, it will not be possible to close the hatch.

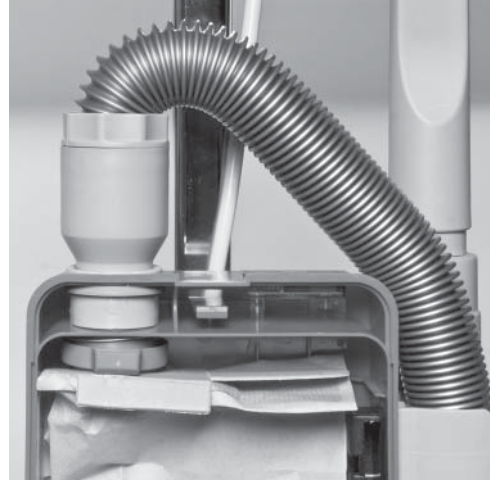

2. FILTER REPLACEMENT

Take out the filter support and replace it or clean it by tapping it gently (the filter needs to be replaced about every 20 dust bags).



3. HEPA FILTER REPLACEMENT; PREFILTER REPLACEMENT OR CLEANING

Depress the black clip (A) to release the ventilation grille and at the same time slide out the grille (in the direction of the arrow) to free it. The prefilter is located in the air outlet area under the Hepa filter. Replace or clean the prefilter by washing it with water, then dry it and put it carefully back in place. Replace the Hepa filter when dirty and reassemble the ventilation grill by sliding it until you hear the clip lock into place.

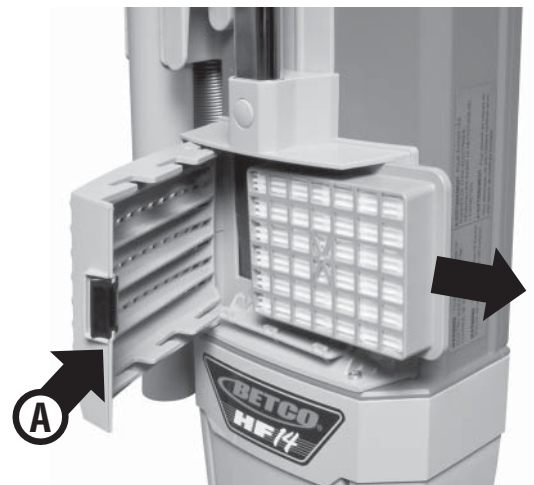

MAINTENANCE

4. REMOVING OBSTRUCTIONS FROM THE EXTERNAL HOSE

- Obstructions can be removed from the hose by sliding the hose out from its seating and starting up the suction function but blocking it intermittently with your hand.
- Do not insert any items to remove obstructions from the pipe.



5. REMOVING OBSTRUCTIONS FROM THE INTERNAL HOSE

- Disconnect power.
- Put the suction unit in a horizontal position in line with the electric brush.
- Remove the screws from the base: remove the base.
- Remove the obstruction from the hose with the aid of a flexible cleaning swab.

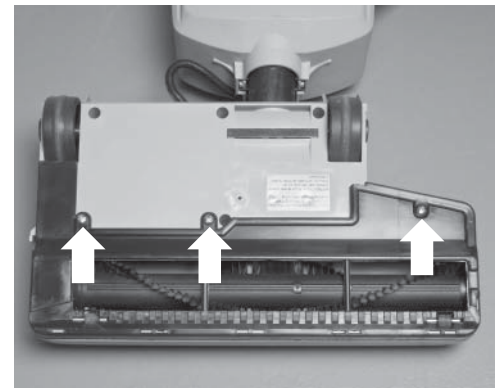

ATTACHMENTS SUPPLIED

- 1 – Small brush
- 2 – Service nozzle
- 3 - Hose
- 4 – Extension

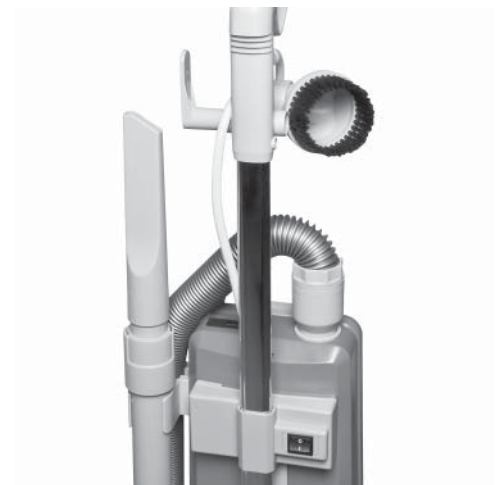

WIRING DIAGRAM

CAUTION! Any job involving the electric equipment must be carried out by qualified personnel only.

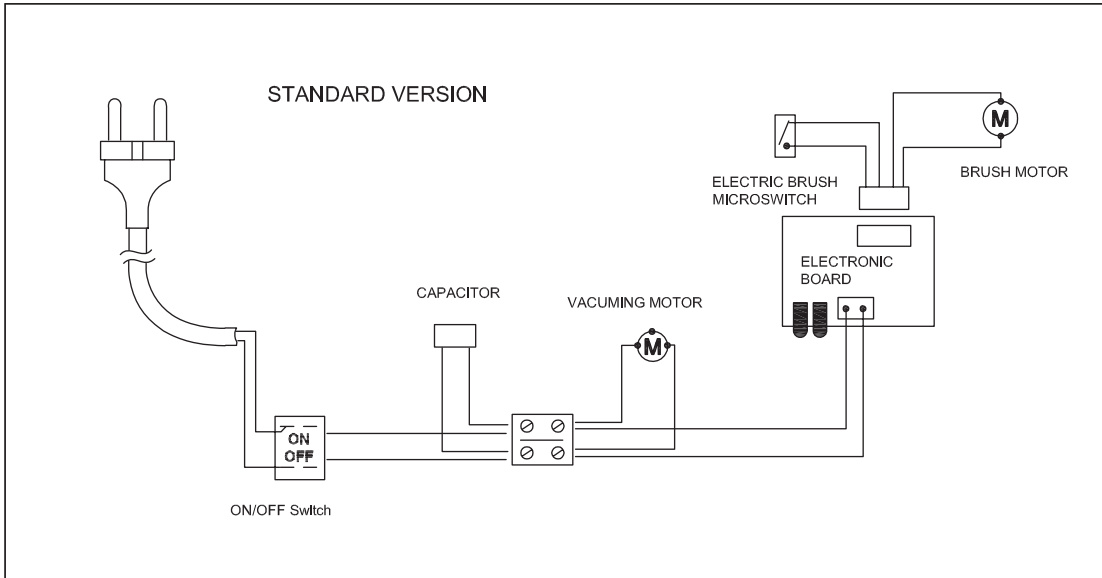

BETCO US WARRANTY POLICY

10 year coverage

Subject to the conditions stated below, Betco warrants parts and labor on rotationally molded polyethylene tanks/housings and injection molded vacuum head assemblies to be free from defects in materials and workmanship for a period of ten years to the original purchaser.

3 Year Coverage

Subject to the conditions stated below, Betco warrants parts and labor on all other Betco components to be free from defects in materials and workmanship for a period of three years to the original purchaser.

1 Year Coverage

Subject to the conditions stated below, Betco offers a limited warranty on parts and labor on the following equipment: parts and accessories to be free from defects in materials and workmanship for a period of one year to the original purchaser.

- HF14 Upright Vacuum: #E88820-00
- Bac Pac Lite Vacuum: #85903-00
- FiberPRO® Floor Dryer: #85507-00
- WORKMAN™ Series Vacuums: #85024-00, #85025-00, #85026-00, #85027-00
- CV100T Vacuum: #85023-00
- All Tools and Accessories
- All Battery Chargers
- All Batteries are pro-rated for 1 year

Allowable Travel Time Warranty Reimbursement:

Eligible equipment: All battery and propane powered equipment products. Warranty period: 90 days from date of sale to the original purchaser. A maximum 60 mile round trip at 44 cents per mile will be allowed for warranty consideration.

Propane Machine Warranty:

Honda engines are warranted by Honda for a period of 2 years against manufacturer defects. Kawasaki engines are warranted by Kawasaki for a period of 2 years against manufacturer defects. All other components (except wear items)* are warranted by Betco for a period of 3 years.

***Wear Items exempt from Warranty consideration include but may not be limited to: power cords, transport wheels, vacuum bags, belts, squeegee blades, pad drivers, clutch plates, handle grips, filters, screens, throttle cables, brushes and carbon brushes.**

Subject to the conditions and exceptions stated in this warranty, Betco warrants the Betco products to be free from defects in material and workmanship, under normal use and service, for the periods listed under the warranty policy to the original purchaser. At any time during the warranty period, Betco will furnish replacement parts for the Betco parts to the original purchaser. Such parts will be furnished and charged including transportation costs, to the original owner through any Betco authorized Service Distributor. If the original part is returned within the warranty policy period from date of delivery for inspection by Betco and is found to be defective the owner will be credited for the cost of replacement parts plus shipping and handling. Replacement parts that have become defective through wear or abuse are not included in this warranty.

This warranty does not apply to damage or defect caused by accident, misuse, negligence, fire, or to any Betco product which has been serviced or repaired by other than an authorized Betco Service Distributor or Betco factory personnel. This warranty is void if products are used for any purpose other than that which was intended. There are no other warranties expressed or implied. In no event shall Betco be liable for incidental or consequential damages or any damage to person or property. (Please note some states do not allow the exclusion or limitations for incidental and consequential damages)

